

Product data sheet

Characteristics

XUZA51S

Fixing bracket, Photoelectric sensors XU,
accessory for sensor, XUK S, stainless steel

Product availability: Non-Stock - Not normally stocked in distribution facility

Price*: 25.00 USD



Main

Range of Product	Telemecanique Photoelectric sensors XU
Accessory / separate part category	Mounting and fixing accessory
Accessory / Separate Part Type	Fixing bracket
Product or Component Type	Fixing bracket
Accessory / separate part destination	Compact sensor 50 x 50 mm
Material	Stainless steel

Complementary

Product Compatibility	XUK_S
Net Weight	0.11 Lb(US) (0.05 kg)

Ordering and shipping details

Category	22499 - SENSORS ACCESSORIES
Discount Schedule	DS2
GTIN	03606480435911
Nbr. of units in pkg.	1
Package weight(Lbs)	1.90 Oz (54 g)
Returnability	No
Country of origin	DE

Packing Units

Unit Type of Package 1	PCE
Package 1 Height	1.22 In (3.1 cm)
Package 1 width	2.91 In (7.4 cm)
Package 1 Length	2.44 In (6.2 cm)

Offer Sustainability

California proposition 65	WARNING: This product can expose you to chemicals including: Diisononyl phthalate (DINP), which is known to the State of California to cause cancer, and Diisodecyl phthalate (DIDP), which is known to the State of California to cause birth defects or other reproductive harm. For more information go to www.P65Warnings.ca.gov
REACH Regulation	REACH Declaration
REACH free of SVHC	Yes
EU RoHS Directive	Pro-active compliance (Product out of EU RoHS legal scope) EU RoHS Declaration
Toxic heavy metal free	Yes
Mercury free	Yes
RoHS exemption information	Yes

Contractual warranty

Warranty	18 months
----------	-----------

Dimensions

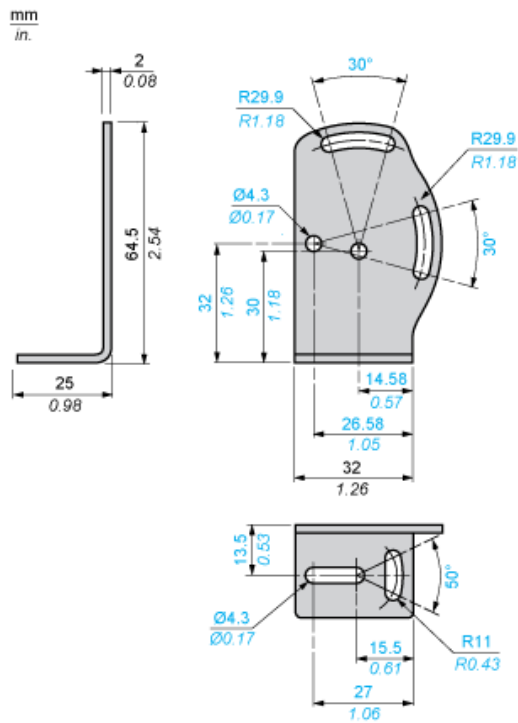

Product Life Status : Commercialised